

Rev.3.1

TB10DA56X – Test board description

TB10DA56X is the test board including 5 double common anode seven segment indicators (red or green, depending of the last character in Part No R-red or G-green) 0,56 inch high (14,22 mm). Also board include shift register 74HCT595, Darlington buffer ULN 2803, 8 Load resistors Anode Connector (20 pin) and 2 Input/Output (10pin) connectors. All necessary signals and Power Supplies for Test board are provided from controller. Cables between Test board and Controller are ribbon (one 20 pin and one 10 pin) must be not longer than 1 m. Each Test board occupied 10 bytes in controllers LED Buffer. Via writing of byte or block of bytes in appropriate address in LED Buffer, controller drives defined segments of selected indicator. After power up two LED buffers are filled with 00h (display is blanc). As noted from the Figure 1, **Q1** refers to address 00h in LED buffer, **Q1** to 01h and **Q10** to 09h. In the next Test board will refer to LED Buffer as follows Q1 to 0Ah, Q2 to 0Bh and etc. Schematic of Test board is shown on **Figure1**.

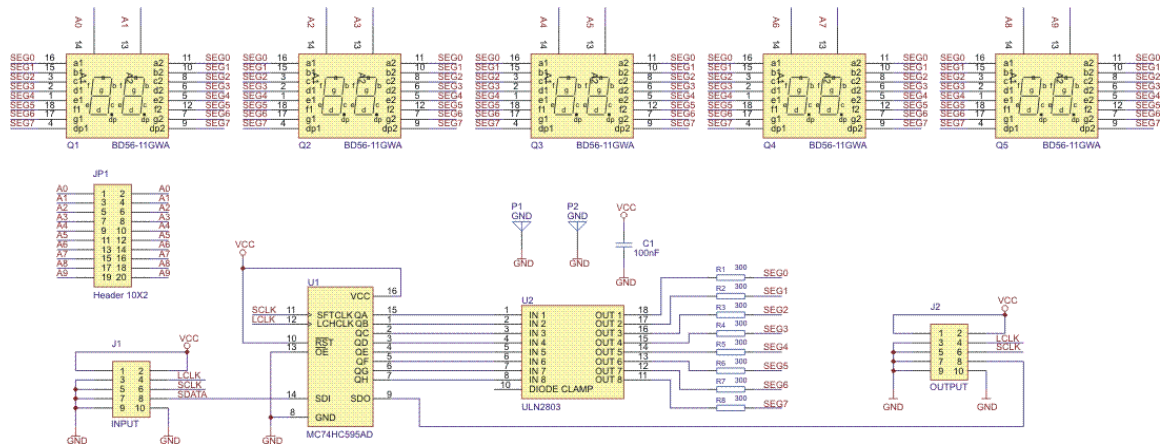

Figure 1

Figure 2 shown Test boards Component Side (dimensions in inches).

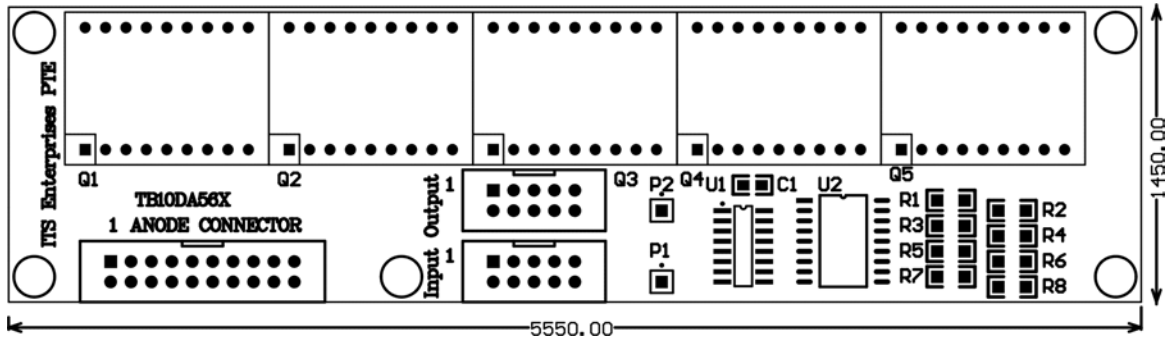
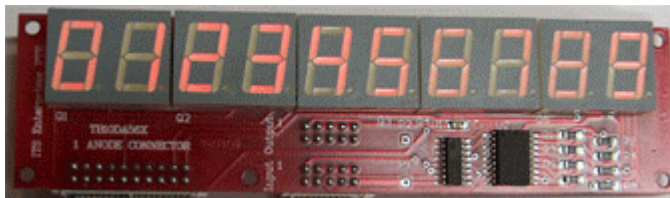

Figure 2



This picture shown one test board with PWM = 01h (1%). All next pictures are made without LED filter and all pictures are clean source (without any corrections).



This picture is lake above with PWM = 31h (50%).



PWM = 62h (99%).

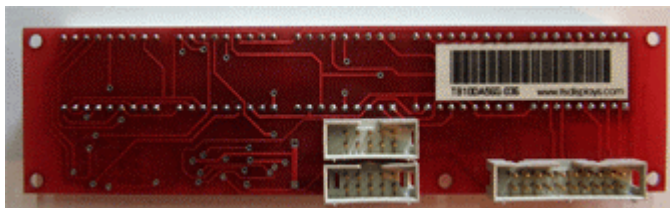

This picture shown Anode connector, Input and Output connectors on the rear side of the Test board

Refer to Web site www.itsdisplays.com to download Schematics and PCB files.